

SPECIFICATION

CONSTRUCTION

Outer Body of every locker cabinet is made of 5 mm thick plates. The top is further reinforced with 10 mm thick m.s. Flat at the front. Inner, horizontal and vertical partitions of lockers cabinets are made of 2 mm m.s. plates. The bottom is strengthened with steel angle section forming a strong structure. The doors are of 10 mm thick steel plates, hang on 16 mm secure solid hinges. The hinges are of interlocking type which provides pillar type support to the doors. Hence, the hinges themselves Act as dog bolts. The doors are covered with anodized aluminum fronts to give an attractive appearance which requires no maintenance. Powder Coated fronts can also be provided at extra cost.

LOCKING DEVICE

Most important part of the locker is fitted with high precision dual control lock. Each lock is composed of two independent locking units activated by two separate keys. Right hand unit is called renters unit and left hand unit is for customer. Lock is opened only when custodian and customer operate keys simultaneously. Custodian removes the key when lock is opened. Custodian's presence is only necessary when locker cabinet needs to be opened.

Additional Renter's Locks

There is a provision for retrofitting an additional renters built-in lock. This can be provided, at an extra cost. In addition, provision for fitting renters own pad locks can also be made, provided that the requirement is made known at the time of placing the order.

FINISH

All parts of the cabinet are subjected to a thorough anti-rust chemical and mechanical treatment, before being applied with a coat of anti-corrosive paint and fine enamel coating.

SAMERIKA CUSTOM MADE LOCKERS

Samerika Custom made Lockers are also provided as per the requirement of customer. These are tailor made non-standard lockers in various sizes & combination.



*Our policy is one of continuous development. Dimensions and specifications may be changed without prior notice or obligation.

OVERALL DIMENSIONS

(APPROX)		
H x W x D		
2000 x 1066 x 575 mm		

SDL-90

SLD - 90

Lockers	Quantity	Approx Internal		
		Height	Width	Depth
A	90	125	179	502mm

SLD - 75

Lockers	Quantity	Approx Internal		
		Height	Width	Depth
A	65	125	179	502mm
C	6	125	360	502mm
F	3	278	360	502mm

SDL-75

SLD - 51

Lockers	Quantity	Approx Internal		
		Height	Width	Depth
B	46	159	215	502mm
E	2	159	434	502mm
H	2	322	434	502mm
H1	1	322	215	502mm

SDL-51

SLD - 32

Lockers	Quantity	Approx Internal		
		Height	Width	Depth
D	28	189	270	502mm
G	2	189	544	502mm
K	2	405	544	502mm

SDL-32

HOW DANGEROUS ONE MAY BE...

TRUST SAMERIKA SAFE COMPANY.



SECURE YOUR TREASURE...



1239 'E', SHAHU MILL ROAD, KOLHAPUR - 416008.
PH : 2527986, 2526369, MOB : 9822057946.
E-mail : samerika@rediffmail.com



COMPANY

There is constant rise in Crime and Criminals are getting more and more sophisticated due to easy availability of modern tools. Banks, Financial Institutions and Jewelers have no option but to have high Security Equipments, which can resist criminal attacks effectively. Samerka has developed a new range of High Security Strong Room Doors, Class I for small Institutions, Class II for big Institutions, Banks as well as for currency chests and custom made Doors for Jewelers.

CLASS I AND CLASS II DOOR

Outer layer of Door slab is of tough tested quality M.S. plate of 12 mm for Class I Door, 14 mm sandwiched plates for special purpose Jewelers Strong Room Door and 32 mm for Class II Door. It is further fortified by a composite 60 mm thick layer of barrier material and layer of flame and arc resistant alloy and hardened steel plates, which provide protection against fire, power drill, oxy-acetylene flame and arc cutting.

DOOR FRAME

Tough tested quality M.S. steel plate of 8 mm for Class I, Jewelers Door and 10 mm for Class II Door bent to make C channel type door frame, the door frame is reinforced along the height and width for Strength and Rigidity.

BOLT WORK AND LOCKING MECHANISM

The door is provided with 12 shooting bolts 6 in front and 6 at the rear, which slide behind the tough rebate of the frame. The movement of the handle can activate these bolts simultaneously. Strong Room Doors are fitted with one 10 lever lock with S.S. keys in duplicate and one U.L. certified mechanical three wheel combination lock.

VENTILATING GRILL GATE

Grill gate is constructed with heavy round bars at staggered pitch and secured with lock operating on both sides provided with stainless keys in duplicate.

OPTIONS

Standard Samerka Doors are right hung, however we can supply non-standard doors as per customers specifications & requirement. We provide accessories such as Tans bars, Emergency door, Combination locks etc. at extra cost.

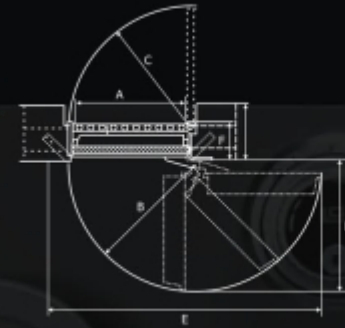

Strong Room Doors Specifications

Particulars		Class II	Class I	Jewelers Door
Recommended for Wall Thickness	WT	380-460	305-380	280-305
Overall Size H x W		2290x1370	2200x1285	1830x915
Clear opening	A	2000x915	2000x915	1675x685
Door Swing	B	1045	1045	790
Grill gate swing	C	1040	1040	815
Projection of door at 90°	D	1100	1100	815
Width of door & frame when fully opened	E	2300	2300	1700
Thickness of door frame including grill gate	F	285	300	275
Weight without packing (approx.)	Kg.	1160	995	585

Tolerance Weight : + - 5 % Dimensions : + - 3 %



SAFE WITH SAFE DEPOSIT LOCKER

Now banks & financial institutes in rural areas who do not have facility of strong room doors, can buy Safe with Safe Deposit Locker. They can give their customers facility of Locker without strong room door.